



COMMUTER 125

COMMERCIAL BUS / VAN

Designed for commercial bus and van markets, the Commuter 125 Seat by Freedman Seating is lightweight, attractive, comfortable and safe. It's executive styling provides a first-class look without compromising weight or safety. Best in class hip-to knee makes this a perfect fit for vans, wagons and buses alike. This high-back seat meets FMVSS 210 and 202A.



see more online
www.freedmanseating.com



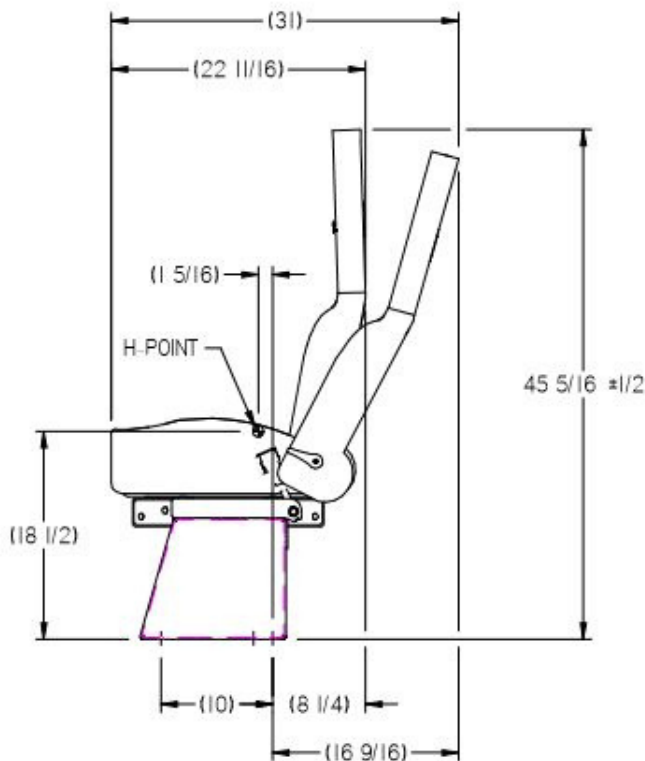
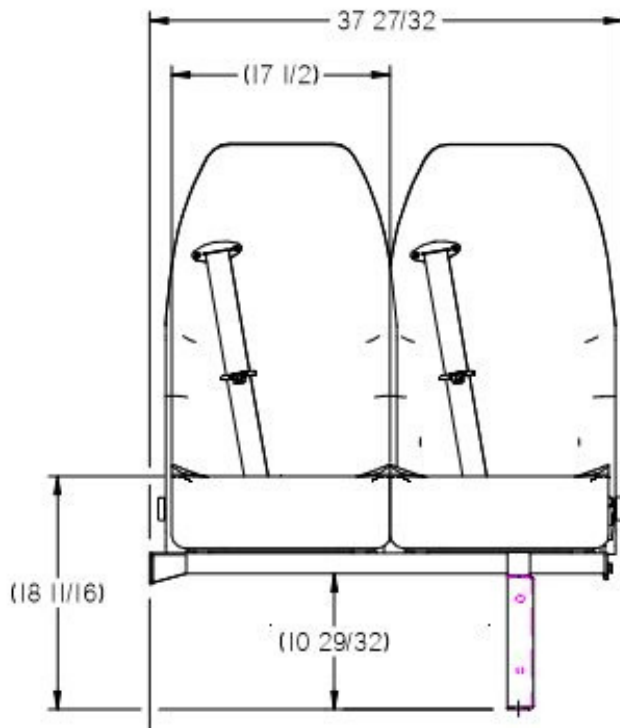

Engineered and tested in the US, it is FMVSS compliant with all regulations including 202A, 225, 207 and 210. The Commuter 125 seat highlights our most space-saving features to-date with a thin back cushion for more hip-to-knee room. Safety is our priority, so the Commuter 125 is available standard with 3-point shoulder belts and switchable KISI ALR for securing removable child seats.

The "125" celebrates our 125th anniversary and the year the new Commuter seat was designed and developed.

features

- Ergonomically correct seat and back
- Recliners
- 17.5" wide cushion
- Seat height reflects the needs of the van and small bus industries, meeting FMVSS 202A
- Molded polyurethane back cushioning for long lasting support and comfort
- 3-point shoulder belts
- Switchable KISI ALR for securing child seats
- All steel construction
- Standard with Milano Vinyl, a high-grade material with the look and feel of leather.

options

- Upholstered Armrest
- Power Outlets (USB and 110v)
- CRS Hooks
- Mesh map pockets
- Contrast stitching
- Ford™ Transition Brackets
- SeatLink™ (coming soon)



FREEDMAN®
SEATING COMPANY

4545 W. Augusta Blvd., Chicago, IL 60651
(773) 524-2440 (800) 443-4540 Fax (773) 252-7450
freedmanseating.com | info@freedmanseating.com



Freedman Seating is committed to lessening our impact on the planet. For your convenience, materials are now available online to download at www.freedmanseating.com.



We are constantly updating and improving our seats; therefore we reserve the right to change or modify specifications or materials without notice. All Freedman Seating Company seats meet or exceed FMVSS standards